

# VendingMiser®

## VM160 / VM161 Outdoor Installation Instructions

VendingMiser® is designed to operate as an intelligent power controller for cold product vending machines. Note that VendingMiser may not be used on any vending machine which contains perishable products.

### General Theory of Operation

Using a Passive Infrared (PIR) occupancy sensor, VendingMiser will automatically shut down the controlled vending machine when the area around the machine has been vacant for 15 minutes. However, VendingMiser will periodically re-power the vending machine automatically to ensure that the vended product stays cold. In addition, VendingMiser contains a current sensor which determines if the vending machine's compressor is operating and will delay power-down of the vending machine until the compressor has completed its cooling cycle.

To install the VendingMiser, follow these simple steps:

### Locating and Mounting the VendingMiser

1. Unplug the vending machine's power cord from the outlet. If it is necessary to move the machine, be careful as it can be heavy. Note- Each vending machine should remain on the same outlet/circuit breaker at the end of installation.
2. Identify a suitable mounting location for the VendingMiser, most likely on the wall adjacent to or behind the vending machine. The VendingMiser must be located so that the machine's power cord can reach VendingMiser, and VendingMiser's power cord can reach the power outlet.
3. Mount the VendingMiser's back plate to wall with suitable fasteners oriented as shown at right so that the side of the plate with the mounting tabs is at the top.
4. "Snap" the VendingMiser DOWNWARDS onto the mounting bracket.
5. Plug the vending machine's power cord into the VendingMiser power outlet cable. Do not yet plug the VendingMiser into the wall outlet or attach the case's cover.

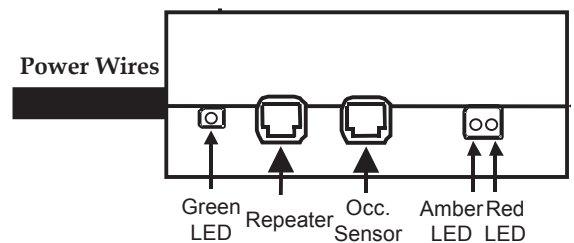

### Occupancy Sensor or Sensor Repeater Installation

6. If this VendingMiser is stand-alone, or the first in a bank of machines, a PIR sensor must be installed to create a Primary VendingMiser. If this VendingMiser is not first in a bank, skip to Step 11 to install a Secondary VendingMiser.
7. The PIR sensor must be located so that it can "See" anyone approaching the vending machine. Ideally, the sensor should be mounted on the wall behind the vending machine, about 2 feet above the machine. To mount the sensor, remove the two screws holding the two-piece mounting arm together shown (picture on next page). **DO NOT** open the sensor itself. When the mounting arm is open, two mounting holes are visible in the rear section of the arm. Use appropriate fasteners to secure the arm's rear housing to the surface on which the sensor will be mounted. Note that the sensor must be mounted horizontally with the label on bottom of the sensor DOWN.
8. Remove the rubber plug in the bottom of the mounting arm of the sensor housing attached to the wall. Thread the supplied phone cord through the opening and plug it into the exposed connector on the sensor as shown in the



Sales & Service:  
888-561-4748  
www.usatech.com

6810 N. Broadway, Unit C  
Denver, Colorado 80221  
303-296-9800

100 Deerfield Lane, Suite 140  
Malvern, Pennsylvania 19355  
610-989-0340

Copyright © 1997-2008  
Revision 12-2008  
Part #23023  
Printed in the U.S.A.

# VendingMiser®

## VM160 / VM161 Outdoor Installation Instructions (cont'd.)

picture on the right. Notch the rubber plug for the sensor cord, and replace it now.

9. Replace the front half of the mounting arm placing it over the sensor's swivel connection. Ensure that excess sensor cord is pulled through the arm and does not bunch up inside the sensor, as this will inhibit sensor rotation. Secure the sensor arm to the sensor using the two screws removed in Step 7, and tilt it down to properly cover the area in front of the vending machine.
10. After carefully uncoiling the sensor cord, plug it into the center socket on the VendingMiser. It is highly recommended that the sensor cable be secured by covering the cable with plastic low voltage wire raceway.
11. If a Secondary VendingMiser is being installed, use the supplied 3 Meter (10 feet) phone style cable to connect the OCCUPANCY SENSOR connector on this Secondary to the REPEATER connector on the Primary VendingMiser. Additional Secondary VendingMisers can be daisy-chained as shown to the right. A maximum of four Misers can be daisy-chained in this fashion. It is acceptable to mix VendingMisers with SnackMisers, PlugMisers, and/or CoolerMisers provided the sensor coverage is acceptable for all devices sharing the sensor.

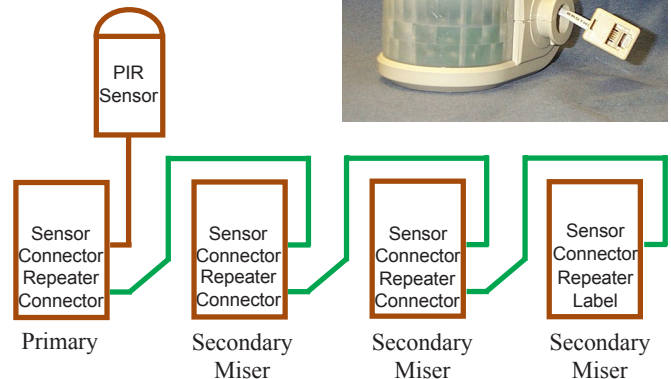

### Power-Up Testing and Install Validation

12. Plug the VendingMiser into the wall outlet. The following should occur:
  - The vending machine should power up immediately.
  - The Green LED should flash twice to indicate that the temperature sensor is functional.
  - The Amber LED should then come on as the VendingMiser attempts to synchronize with the compressor's operation. This typically will require that the compressor cycle on and off.
  - The Red LED should come on, indicating occupancy detection.



The PIR sensor must be allowed to stabilize for several minutes before its placement can be verified. Once the sensor is warmed up, it will flash at the slightest movement within its field of view. Validate that the sensor can "See" an occupant at, or approaching, the vending machine. If necessary, relocate or adjust the sensor and repeat the coverage test. The Red LED on the VendingMiser will mirror the state of the PIR sensor, with an additional 3 second delay. This verifies that VendingMiser is communicating with the PIR sensor.

13. As a final functional test, the VendingMiser will power-down the first time only after installation approximately two minutes after the area around the machine is vacant and the compressor is determined to be not running. Covering the PIR sensor or temporarily setting it to face the wall will allow validation of the power-down operation if so desired. Following this initial power-down, the VendingMiser will operate with standard time-outs.
14. Secure the weatherproof housing cover over the VendingMiser with the supplied screws as shown above.

**NOTE:** The VendingMiser will flash all three LEDs simultaneously and light a RED LED in the PIR sensor if the vending machine has failed and will not shut down its compressor after several hours of use. Since this prohibits the VendingMiser from shutting down the machine, please call the machine owner service line for machine service.



Sales & Service:  
888-561-4748  
www.usatech.com

6810 N. Broadway, Unit C  
Denver, Colorado 80221  
303-296-9800

100 Deerfield Lane, Suite 140  
Malvern, Pennsylvania 19355  
610-989-0340

Copyright © 1997-2008  
Revision 12-2008  
Part #23023  
Printed in the U.S.A.